

MOTOR ACTUATED BUTTERFLY VALVE FOR DOUBLE "Y" AIR OUTLET OR TELESCOPIC DUCT

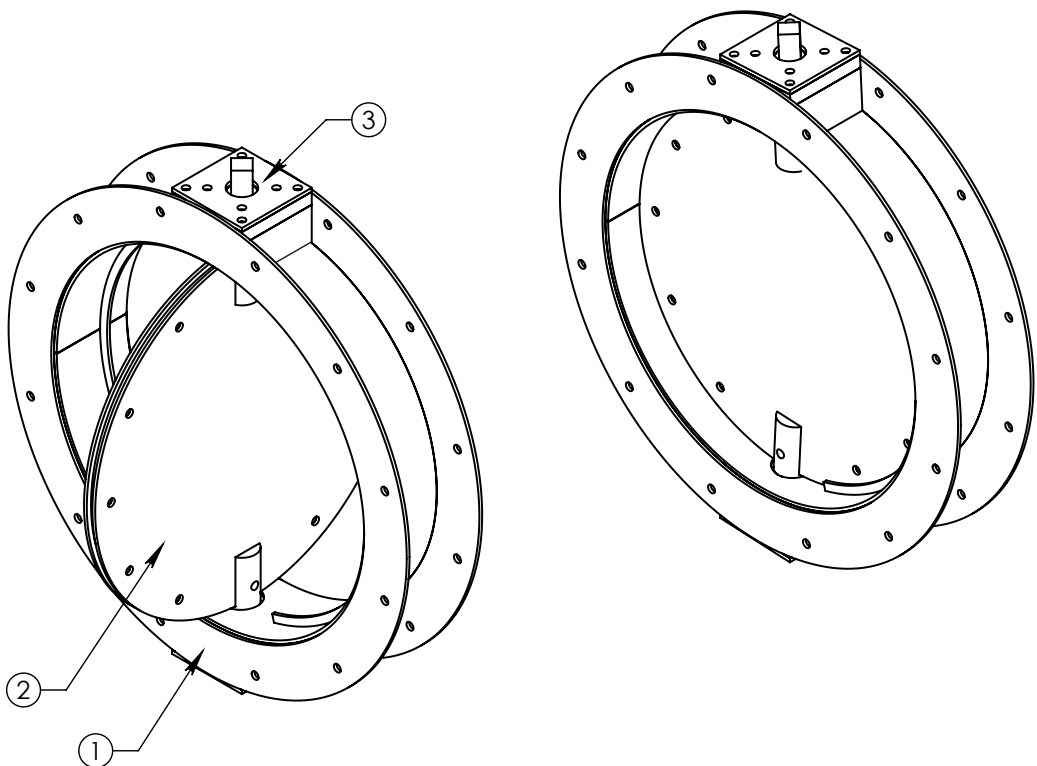

- Body manufactured in AISI 304 Stainless Steel
- Valve manufactured in Stainless Steel, 8+8 mm thick
- Air tightening ring in silicon rubber
- Dimensions: Ø 570 mm x 108 mm

MOTOR ACTUATOR



- **Electrical data Nominal voltage AC/DC 24 V**
- Nominal voltage frequency 50/60 Hz
- Nominal voltage range AC 19.2...28.8 V / DC 21.6...28.8 V
- **Functional data Torque motor Min. 40 Nm**
- Torque variable 25%, 50%, 75% reduced
- Positioning signal Y DC 0...10 V
- Positioning signal Y note Input impedance 100 k Ω
- Control signal Y variable Open-close
- 3-point (AC only)
- Modulating (DC 0...32 V)
- Position accuracy $\pm 5\%$
- Direction of motion motor selectable with switch 0 / 1
- Direction of motion variable electronically reversible
- Manual override with push-button, can be locked
- Angle of rotation Max. 95°
- Angle of rotation note can be limited on both sides with adjustable
- Mechanical end stops
- Running time motor 45 s / 90°
- Override control MAX (maximum position) = 100%
- MIN (minimum position) = 0%
- ZS (intermediate position, AC only) = 50%
- Override control variable MAX = (MIN + 32%)...100%
- MIN = 0%...(MAX - 32%)
- ZS = MIN...MAX
- Sound power level motor 45 dB(A)